

Date: - 04.11.2022

To
Ministry of Environment, Forest and Climate Change
Regional Office,
Ground Floor, New Secretariat Building, Civil Lines,
Nagpur – 440001, Maharashtra.

Sub: Submission of Six monthly Compliance report for Construction Project located Survey No. 70/1 and S. No. 65/1/1B, Mouje Wakad, Tal. Mulashi, Dist. Pune by Akanksha Builders.

Ref: Environment Clearance from SEIAA of Maharashtra no. SEIAA-EC-22B038MH158171 Dated 10.01.2022

Respected Sir,

We have Proposed expansion of residential cum commercial construction Project located at Survey No. 70/1 and S. No. 65/1/1B, Mouje Wakad, Tal. Mulashi, Dist. Pune by Akanksha Builders. We are submitting herewith the six monthly compliance for the months January 2022 –June 2022.

Now we are applying for expansion of existing EC. Therefore, we request you to visit our site and certify the conditions mentioned in SEIAA of Maharashtra no. SEIAA-EC-22B038MH158171 Dated 10.01.2022.

Thanking you,

Yours Faithfully,

Akanksha Builders



Authorized Signatory



 214, The Pentagon, Off Pune Satara Road,
Next to Telephone Exchange, Parvati,
Pune-411 009.

 +91 20 2422 2844 | 2422 2855

 info@akankshabuilders.com

 www.akankshabuilders.com

Monitoring the implementation of Environmental Safeguards

Ministry of Environment, Forest & Climate Change

Regional Office (West Central Zone), Nagpur

Monitoring Report

Part – I

Data Sheet

1.	Project Type: River-valley / Mining / Industry/Thermal / Nuclear / Other (Specify)	Residential cum Commercial Construction project
2.	Name of the project	
3.	Clearance Letter (s) / OM No. and date	EC Identification No.EC-22B038MH158171 Dated 10.01.2022
4.	Location a. District (s) b. State (s) c. Latitude d. Longitude	a. Pune b. Maharashtra c. 18°35'45.90"N d. 73°44'38.01"E
5.	Address for correspondence a. Address of concerned Project chief Engineer (with pin code & Telephone/Numbers) & Address of Executive Project Engineer / Manager (with pin code/fax numbers)	Mr.Rahul Paigude ThePentagonBuilding,officeno.213, Off Pune -Satara Road, Near Hotel Panchami,ParvatiDist. Pune.
6.	Salient Features a. Of the Project b. Of the Environmental Management Plan	a.Salient feature of the project Location: S. No. 70/1 andS. No. 65/1/1B, MoujeWakad,Tal.Mulashi,Dist.Pune Total Plot area: 12,491.72 m ² Total Proposed built up area: 64500 m ² Expected users: 2767 Water requirement: Total : 305 KLD Fresh: 192 KLD Recycled: 264 KLD Source: PCMC STP capacity: 250 KLD (Residential) + 30 KLD (Commercial) Rain water Harvesting: Recharge pits : 4 No. Wet waste: 651 Kg/day

📍 214, The Pentagon, Off Pune Satara Road,
Next to Telephone Exchange, Parvati,
Pune-411 009.

☎ +91 20 2422 2844 | 2422 2855

✉ info@akankshabuilders.com

🌐 www.akankshabuilders.com

		<p>Dry Waste: 487 kg/day E waste: 1615 kg/day</p> <p>b) Salient feature of the Environmental Management Plan</p> <ol style="list-style-type: none"> 1. Water demand reduces as water will be reused for the flushing and irrigation purpose. 2. Wet waste will be treated in the own premises and manure will be used for landscaping 3. Proposed recharge pits to recharge the ground water. 4. Provision of Energy conservation measures 5. Proposed landscape and tree plantation
7.	<p>Breakup of the project area</p> <ol style="list-style-type: none"> a. Submergence Area: Forest & Non Forest b. Others 	Not applicable
	<ol style="list-style-type: none"> a. Total Plot Area 	12491.72 m ²
	<ol style="list-style-type: none"> b. Built – up Area 	64500.00 m ²
	<ol style="list-style-type: none"> c. Open Space 	1050.00 m ²
	<ol style="list-style-type: none"> d. Landscape Area 	2682.24m ²
8.	<p>Breakup of the project affected population with enumeration of those losing houses/dwelling units & landless laborers/artisan</p> <ol style="list-style-type: none"> a. SC, ST/Adivasis b. Others <p>(Please indicate whether these figures are based on any scientific and systematic survey carried out gives details and years of survey.)</p>	Not Applicable
9.	<p>Financial Details</p> <ol style="list-style-type: none"> a. Project costs as originally planned & subsequent revised estimates and the year of price reference. b. Allocations made for Environmental Management Plan with item wise & year wise breakup. c. Benefit Cost Ratio / Internal rate of return and the year of assessment. d. Whether (c) includes the cost of Environmental Management as shown in the above. 	<ol style="list-style-type: none"> a. Project cost: 97 Crs. b. Capital Cost: 540 Lakhs and O & M cost: 39 Lakhs/p.a. c. Not Applicable d. Not applicable
10.	<p>Forest Land Requirement</p> <ol style="list-style-type: none"> a. The status of approval for diversion of forestland for non-forestry use b. The status of Clearing felling 	Not Applicable

	c. The status of Compensatory Afforestation programme in the light of actual field experience.	
11.	The status of clear felling in non-forest areas (such as submergence area of reservoir, Approach roads), if any with quantitative information required	Not Applicable
12.	Status of construction a. Date of commencement (Actual and/or Planned) b. Date of completion (Actual and/or Planned)	a. Planned date of commencement: 19/04/22 b. Planned date of completion: 20/04/27
13.	Reasons for the delay if the project is yet to start	NA
14.	Dates of site visits a. The dates on which the project was monitored by Regional office on previous occasions, if any b. Date of site visit for this monitoring report	No site visit done so far
15.	Details of correspondence with project authorities for obtaining action plan / information on status of compliance to safeguards other than the routine letters for logistic support for site visit. (The monitoring report may obtain the details of all the later reports may cover only the letters issued subsequently)	Not Applicable
Letter From RO		Reply from PA

Thanking You,

Yours Faithfully,

For Akanksha Builders

Authorized Signatory



Compliance to the conditions stipulated in the Environmental Clearance issued by Ministry of Environment, Forest & Climate Change obtained vide letter no. SEIAA EC22B038MH158171 dated 10/01/2022, for expansion of residential cum commercial project at Survey No. 70/1 and 65/1B, Mouje Wakad, Tal. Mulashi, Dist Pune By Akanksha Builders.

Period of Report: January'2022 to June '2022

S.N.	Description	Present Status (Yes/No)
	Specific Conditions	
A	SEAC Conditions	
1	PP to submit the MoD NoC.	MoD Copy is attached as Annexure I
2	PP to submit the details of electricity generation through solar PV panels.	Details attached as Annexure II
3	PP to provide minimum 30% of total parking arrangements with electric charging facility by providing charging points at suitable places.	Agreed
B	SEIAA Conditions	
1	PP to keep open spaces unpaved as so to ensure permeability of water. However, whenever paving is deemed necessary, PP to provide grass pavers types & strength to increase the water permeable area as well as to allow effective fire tender movement.	Agreed
2	PP to achieve at least 5% of total energy requirement from solar/other renewable sources.	Agreed
4	PP Shall comply with Standard EC conditions mentioned in the Office Memorandum issued by MoEF & CC vide F.No.22-34/2018-IA.III dt.04.01.2019.	Agreed
5	SEIAA decided to grant EC for – FSI: 40258.87 m2, Non-FSI:24241.13 m2 and Total BUA: 64500.00 m2 (Plan approval – BP/EC/Wakad/09/2021 dated 08.10.2021)	Environmental clearance is received vide no. EC Identification No. EC22B038MH158171 dated 10/01/2022. Attached as Annexure III.
	General Conditions	
a)	Construction Phase	
I.	The solid waste generated should be properly collected and segregated. Dry/inert solid waste should be disposed off to the approved sites for land filling after recovering recyclable material.	Agreed.
II	Disposal of muck during construction phase should not create any adverse effect on the neighboring communities and be disposed taking the necessary precautions or general safety and health aspects of people only in approved sites with the approval of competent authority.	Agreed.

 214, The Pentagon, Off Pune Satara Road, Next to Telephone Exchange, Parvati, Pune-411 009.

 +91 20 2422 2844 | 2422 2855

 info@akankshabuilders.com

 www.akankshabuilders.com

III.	Any hazardous waste generated during construction phase should be disposed off as per applicable rules and norms of necessary approvals of Maharashtra pollution control board.	Agreed.
IV.	Adequate drinking water and sanitary facilities should be provided to construction workers at the site. Provision should be made for mobile toilets. The safe disposal of wastewater and solid waste generated during the construction phase should be ensured.	Agreed.
V.	Arrangement shall be made that wastewater and storm water do not get mixed up.	Agreed.
VI.	Water demand during construction shall be reduced by use of pre-mixed concrete, queering agents and other best practices.	Agreed
VII.	The ground water level and its quality should be monitored regularly in consultation with Ground Water Authority.	One Well is present at plot boundary.
VIII.	Permission to draw and use ground water for construction of basement if any shall be obtained from competent authority prior to construction and operation of the project.	No extraction of ground water in construction and operation phase.
IX.	Fixtures for showers, toilet, flushing and drinking should be low flow either by use of aerators or pressure reducing devices or sensor based controls.	Agreed
X.	Energy Conservation Building Code shall be strictly adhere to	Agreed
XI.	All top soil excavated during construction activities should be stored for use in horticulture/landscape development within the project site	Agreed
XII.	Additional soil for leveling of the proposed site shall be generated within the sites (to the extent possible) so that natural drainage system of the area is protected and improved.	Agreed
XIII.	Soil and ground water samples will be tested to ascertain that there is no threat to groundwater quality by leaching of heavy metals and other toxic contaminants.	Soil testing reports and Water report is attached as Annexure IV.
XIV.	PP to strictly adhere to all the conditions mentioned in Maharashtra (Urban Area) Protection and preservation of Trees Act,1975 as amended during the validity of environment Clearance.	Noted
XV.	The diesel generator sets to be used during construction phase should be low sulphur diesel type and should conform to Environment (Protection) Rules prescribed for air and noise emission standards.	Agreed
XVI.	PP to strictly adhere to all the conditions mentioned in Maharashtra (Urban Area) Protection and preservation of Trees Act,1975 as amended during the validity of environment Clearance.	Noted
XVII.	Vehicles hired for the transportation of Raw material shall strictly comply the emission norms prescribed by Ministry of Road Transport & Highway Department. The vehicle shall be adequately	Agreed

	covered to avoid spillage and leakage.	
XVIII.	Ambient noise level should conform to residential standards both during day and night. Incremental pollution load on the ambient air and noise quality should be closely monitored during construction phase. Adequate measures should be made to reduce ambient air and noise level during construction phase, so as to conform to the stipulated standards by CPCB/MPCB	Ambient air and Noise reports attached as Annexure V.
XIX	Diesel power generating sets proposed as source of backup power for elevators and common area illumination during operation phase should be of enclosed type and conform to rules made under the Environment (Protection) Act 1986. The height of stack of DG sets should be equal to the height needed for the combined capacity of all proposed DG sets. Use low sulphur diesel. The location of the DG sets may be decided with in consultation with Maharashtra pollution Control board	Noted
XX	Regular supervision of the above and other measures for monitoring should be in place all through the construction phase so as to avoid disturbances to surroundings	Agreed
b)	Operation Phase	
I.	a) The solid waste generated should be properly collected and segregated. b) Wet waste should be treated by Organic Waste Converter and treated waste (Manure) should be utilized in the existing premises for gardening. And, no wet garbage will be disposed outside the premises. c) Dry/inert solid waste should be disposed of to the approved sites for land filling after recovering recyclable material.	Agreed
II.	E- Waste shall be disposed through authorized vendor as per E-waste (Management and Handling) Rules 2016.	Agreed, E waste will be disposed through the authorized vendor.
III.	a) The installation of Sewage Treatment plant should be certified by an independent expert and a report in this regard should be submitted to the MPCB and Environment Dept. before the project is commissioned for operation. Treated effluent emanating from STP shall be recycled/refused to the maximum extent possible. Treatment of 100% gray water by decentralized treatment should be done. Necessary measures should be made to mitigate the odour problem from STP. b)PP to give 100 % treatment to sewage/Liquid waste and explore the possibility to recycle at least 50 % of water, Local Authority should ensure this.	Agreed
IV.	Project proponent shall ensure completion of STP, MSW disposal facility, Green belt development prior to occupation of the buildings. As agreed during the SEIAA meeting, PP to explore possibility of utilizing excess treated water in the adjacent area of gardening before discharging it into sewer line. No physical	Agreed.

	occupation or allotment will be given unless all above said environmental infrastructure is installed and made functional including water requirement.	
V.	The occupancy certificate shall be issued by the local planning authority to the project only after ensuring sustained availability of drinking water, connectivity of sewer line to the project site and proper disposal of treated water as per environmental norms.	Noted
VI.	Traffic congestion near the entry and exit points from the roads adjoining the proposed site must be avoided. Parking should be fully internalized, and no public space should be utilized.	Agreed
VII.	PP to provide adequate electric charging points for electric vehicles (EVs)	Agreed
VIII.	Green belt development shall be carried out considering CPCB guidelines including selection of plant species and in consultation with the local DFO/ Agriculture Dept.	Agreed
IX.	A separate environment management cell with qualified staff shall be set up for the implementation of the stipulated environmental safeguards.	Noted
X.	Separate funds shall be allocated for implementation of environmental protection measures/EMP along with item-wise-break-ups. These costs shall be included as part of the project cost. The funds earmarked for the environment protection measures shall not be diverted for the other purposes.	Noted
XI.	The project management shall advertize at least in two local newspapers widely circulated in the region around the project, one of which shall be in the Marathi language of the local concerned within seven days of issue of this letter, informing that the project has been accorded EC and copies of EC letter are available with Maharashtra Pollution Control Board and may also be available at website at http://parivesh.nic.in	Advertized is given in the two local news paper on 21.10.2022 Advertisement is attached as Annexure VI .
XII.	Project proponent should submit half yearly compliance reports in respect of the stipulated prior Environmental Clearance terms and conditions in hard & soft copies to the MPCB & this department, on 1 st June & 1 st December of each calendar year.	Noted
XIII.	A copy of the EC letter shall be sent by proponent to the concerned Municipal corporation and the local NGO, if any, from whom suggestions/representations, if any, were received while processing the proposal. The clearance letter shall also be put on the website of the company by the PP.	Noted
XIV.	The proponent shall upload the status of compliance of the stipulated EC conditions, including results of the monitored data on their website and shall update the same periodically. It shall simultaneously be sent to the regional office of MoEF, the respective Zonal office of CPCB and SPCB. The criteria pollutant	Noted

	levels namely; SPM, RSPM, SO ₂ , NO _x (ambient levels as well as stack emissions) or critical sector parameters, indicated for the project shall be monitored and displayed at a convenient location near the main gate of the company in the public domain.	
c)	General EC Conditions	
I.	PP has to abide by the conditions stipulated by SEAC & SEIAA	Agreed
II.	If applicable "Consent for Establishment" shall be obtained from Maharashtra Pollution Control board under Air and Water Act and a copy shall be submitted to the Environment Department before start of any construction work at the site.	Yes, Consent to Establish certificate vide no. Format 1.0/BO/JD(WPC)/UAN No.0000118095/CE-2111000788 dated 18/11/2021 is attached Annexure VII.
III	Under the provision of Environment (Protection) act 1986, legal action shall be initiated against the project proponent if it was found that construction of project had started without obtaining Environmental Clearance.	EC Identification No. EC22B038MH158171 dated 10/01/2022. Attached as Annexure III.
IV.	The Project Proponent shall also submit six monthly reports on the status of the compliance of the stipulated EC conditions including results of monitored data (both in hard copies as well as by e-mail) to the respective Regional office of MoEF, the respective Zonal office of CPCB and SPCB	Agreed
V.	The environmental statement for each financial year ending 31 st March in form-V as in mandated to be submitted by the PP to the concerned SPCB as prescribed under the Environment Protection Rules, 1986, as amended subsequently, shall also be put on the website of the company along with the status of compliance of EC conditions and shall also be sent to the respective Regional Offices of MoEF by e-mail.	Agreed
VI.	No further expansion or modifications other than mentioned in the EIA notification 2006 and its amendments shall be carried out without prior approval of the SEIAA. In case of deviations or alterations in the project proposal from those submitted to SEIAA for clearance, a fresh clearance should be made to the SEIAA as applicable to assess the adequacy of conditions imposed and to add additional environmental protection measures required if any.	Agreed
VII.	This environmental clearance is issued subject to obtaining NOC from Forestry & Wild life angle including clearance from the standing	
	committee of the national Board for Wild life as if applicable & this environment clearance does not necessarily implies that Forestry & Wild Life clearance granted to the project which will be considered separately on merit.	Noted

VII.	This environmental clearance is issued subject to obtaining NOC from Forestry & Wild life angle including clearance from the standing	
	committee of the national Board for Wild life as if applicable & this environment clearance does not necessarily implies that Forestry & Wild Life clearance granted to the project which will be considered separately on merit.	Noted
4.	The Environmental clearance is being issued without prejudice to the action initiated under EP Act or any court case pending in the court of law and it does not mean that PP has not violated any environmental laws in the past and whatever decision under EP act of the Hon'ble court will be binding on the PP. hence this clearance does not give immunity to the PP in the case filed against him, if any or action initiated under EP Act	Agreed
5	This environmental clearance is issued purely from an environment point of view without prejudice to any court cases and all other applicable permissions/NOCs shall be obtained before starting proposed work at site.	Agreed
6	In case of submission of false document and non-compliance of stipulated conditions, Authority/ Environment Department will revoke or suspend the EC without any intimation and initiate appropriate legal action under EP Act, 1986	Agreed
7	Validity of EC: The environmental clearance accorded shall be valid as per EIA Notification 2006 amended time to time	Noted
8	The above stipulations would be enforced among others under the Water (Prevention and Control of Pollution) Act, 1974, the Air (Prevention and Control of Pollution) Act, 1981, The Environment Protection Act, 1986 and rules there under, Hazardous Wastes (Management and Handling) Rules, 1989 and its amendments, the public liability Insurance Act, 1991 and its amendments.	Noted
9	Any appeal against this EC shall lie with the National Green Tribunal, (Western Zone Bench, Pune) New Administrative Building, 1 st Floor D-wing, opposite Council Hall, Pune, if preferred, within 30 days as prescribed under section 16 of the National Green Tribunal Act 2010.	Noted

Thanking You
Yours Faithfully,
For Akanksha Builders

Alital

Authorized Signatory



Annexure I – Copy of MoD NoC



Pimpri Chinchwad Municipal Corporation
Pimpri - 18.
Building Permission Department
Outward No. BP/SEC/173 /2021
Date:- 06 / 10/2021

SITE ELEVATION CERTIFICATE

Name of Developer /Owner:- M/s. Akanksha Builders Through Mr. Nihal Shaikh

Name of Architect:- MR. Avinash Nawathe

Name of Village:- WAKAD, TALUKA- HAVELI, DISTRICT- PUNE

Site Address:- SURVEY NO. 70/1 & 65/1/1B, Wakad, Pune - 411057.

Ref:-MONARCH/PMC MONARCH/PMC-AAI/AN_6243, Dated - 21/05/2021

Sr. no.	Description of pillars	Co-ordinates (in WGS84)		AMSL Height of Co-ordinates given in column (c) in meters	Aerial Distance between Co-ordinates given in column (c) and ARP of NDA, Pune km	Aerial Distance between Co-ordinates given in column (c) and ARP of ARP LOHEGAON, pune km	Remark
		(A)	(B)				
		Latitude	Longitude				
1	Point No. P1 - Differential GPS observation taken on Ground IN STATIC mode	18°35'47.48"	73°44'34.14"	569.5	14.2 km	18.7 km	
2	Point no. P2- Differential GPS observation taken on Ground IN STATIC mode	18°35'47.66"	73°44'35.76"	570.4	14.2 km	18.7 km	
3	Point no. P3- Differential GPS observation taken on Ground IN STATIC mode	18°35'47.67"	73°44'37.87"	571.2	14.2 km	18.6 km	
4	Point no. P4- Differential GPS observation taken on Ground IN STATIC mode	18°35'47.64"	73°44'39.81"	571.5	14.2 km	18.5 km	
5	Point no. P5- Differential GPS observation taken on Ground IN STATIC mode	18°35'46.09"	73°44'39.80"	570.7	14.1 km	18.5 km	
6	Point no. P6- Differential GPS observation taken on Ground IN STATIC mode	18°35'44.50"	73°44'39.78"	570.3	14.1 km	18.5 km	
7	Point no. P7- Differential GPS observation taken on Ground IN STATIC mode	18°35'43.91"	73°44'41.24"	570.0	14.1 km	18.5 km	
8	Point no. P8- Differential GPS observation taken on Ground IN STATIC mode	18°35'44.23"	73°44'38.31"	569.7	14.1 km	18.6 km	
9	Point no. P9- Differential GPS observation taken on Ground IN STATIC mode	18°35'44.39"	73°44'38.31"	569.8	14.1 km	18.6 km	

10	Point no. P10- Differential GPS observation taken on Ground IN STATIC mode	18°35'45.04"	73°44'37.26"	569.8	14.1 km	18.6 km
11	Point no. P11- Differential GPS observation taken on Ground IN STATIC mode	18°35'46.43"	73°44'35.31"	568.6	14.2 km	18.7 km
12	Point no. P12- Differential GPS observation taken on Ground IN STATIC mode	18°35'46.78"	73°44'34.51"	569.6	14.2 km	18.7 km

Total height of Building from Sea surface-

AMSL – 571.5 + Building height – 63.50 (B+G+P +16 floors + Staircase + Water Tank)
=635.00 Mt.

(As per CCZM Height Limit for Zone N6-737 M.)

Note :-

- 1) Building height 63.50 m
- 2) Co-ordinates given in column (c) of above table are of Points shown by applicant at his site, These co-ordinates are based on observations of hand help GPS instrument in STATIC mode there are in WGS84 co-ordinate system.
- 3) The heights given in column (D) are based on the Height of Reference station which is connected to SOI GTS BM using DT leveling.
- 4) Accuracy of Co- ordinates is $\pm 1m$. and Aerial distance rounded off up to first decimal of km.
- 5) The site certificate is prepared with reference to certificate issued by Monarch surveyors with conditions mentioned above.
- 6) Co-ordinate and AMSL is given by M/s. Monarch Surveyors and Engineering Consultants Pvt. Ltd. Who is appoint by Joint Secretary of Government Of India, Ministry of Rural Development, Department of Land Resources (Letter No. 18015/14/2015-LRD Date -09 Aug 2016) And verified by Executive Engineer and Deputy Engineer of PCMC.

(Mr. Rajendra Dumbre)

Deputy Engineer

Building Permission Department

(Mr. Sunil Bhagwani)

Executive Engineer

Building Permission Department

Copy To –

- 1) M/s. Akanksha Builders Through Mr. Nihal Shaikh
- 2) Wing Commander
Station Work office,
Air Force Station Lohegaon.
Pune – 411032.
- 3) Building Permission Department

Annexure II – Energy Details

Single Line Diagram of Rooftop Facility for Net Metering Interconnection

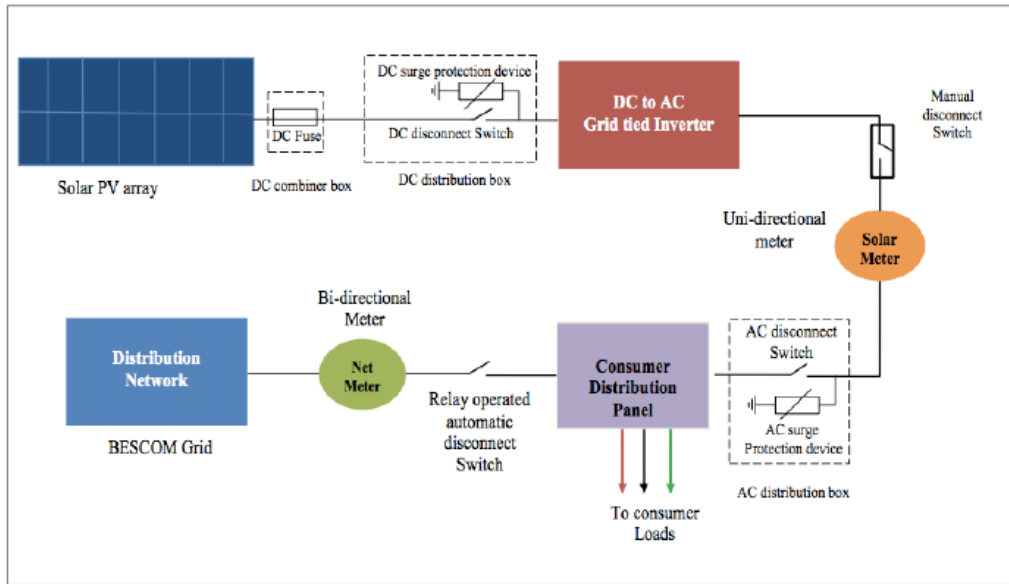

- Solar PV ON GRID system itself describe that we can connect it to the electricity distribution company grid power through NET metering.
- Net metering is only the mechanism to count the NET units exported (from solar) Vs the units imported (from grid).
- Because of this each of the consumer get credit units balance in monthly bill of the electricity distribution company and thus helped to reduce the monthly outflow of electricity charges.
- The system inverter converts DC current (generated by Solar PV) into AC & the self synchronized MPPT (Maximum Power Point Tracker) inverter delivers solar power to the grid.
- It is absolutely maintenance free system & only cleaning of panels is required.
- Space required for the system- Approximate 100 Sq Ft per 1 KW Panel.
- Generally the warranty of solar panel is for 25 years & 5 years for inverter.

TECHNICAL DETAILS

- **Solar Panels:**
Wattage: 390 Wp or More, Efficiency: 19% ~ 19.5%, Operating Conditions: -40 to 85°C.
- **The generation per KW in a day (5 hours is the average working hours of solar panel) are 4.5 to 5 KWH. In this project the capacity being 50 KW, total generation shall be approximately 220 – 250 KWH.**

- **PCU(Inverter):**
Efficiency: > 95%, Power factor: >0.9

Considerations: Covered area for the installation of PCU/ Inverter should be minimum and less than 10Mtrs from the solar PV Array.

- **All Components are generally in line with the prevailing MNRE specifications/IS/IEC standards.**

**Annexure III – Environmental Clearance
Copy**



Government of India
Ministry of Environment, Forest and Climate Change
(Issued by the State Environment Impact Assessment
Authority(SEIAA), Maharashtra)

To,

The Partner
AKANKSHA BUILDERS
Sr.No. 70/1 and Sr.No.65/1/1B, Mouje - Wakad -411057

Subject: Grant of Environmental Clearance (EC) to the proposed Project Activity under the provision of EIA Notification 2006-regarding

Sir/Madam,

This is in reference to your application for Environmental Clearance (EC) in respect of project submitted to the SEIAA vide proposal number SIA/MH/MIS/217615/2021 dated 01 Jul 2021. The particulars of the environmental clearance granted to the project are as below.

- | | |
|--|---|
| 1. EC Identification No. | EC22B038MH158171 |
| 2. File No. | SIA/MH/MIS/217615/2021 |
| 3. Project Type | New |
| 4. Category | B2 |
| 5. Project/Activity including Schedule No. | 8(a) Building and Construction projects |
| 6. Name of Project | Proposed residential cum commercial construction project S. No. 70/1 and S. No. 65/1/1B, Mouje Wakad, Tal. Mulashi, Dist. Pune by Akanksha Builders |
| 7. Name of Company/Organization | AKANKSHA BUILDERS |
| 8. Location of Project | Maharashtra |
| 9. TOR Date | N/A |

The project details along with terms and conditions are appended herewith from page no 2 onwards.

Date: 10/01/2022

(e-signed)
Manisha Patankar Mhaiskar
Member Secretary
SEIAA - (Maharashtra)

Note: A valid environmental clearance shall be one that has EC identification number & E-Sign generated from PARIVESH. Please quote identification number in all future correspondence.

This is a computer generated cover page.

PARIVESH

(Pro-Active and Responsive Facilitation by Interactive,
and Virtuous Environmental Single-Window Hub)



STATE LEVEL ENVIRONMENT IMPACT ASSESSMENT AUTHORITY

Environment & Climate
Change Department
Room No. 217, 2nd Floor,
Mantralaya, Mumbai- 400032.

To
M/s. Akanksha Builders,
S. No. 70/1 and S. No. 65/1/1B,
Mouje Wakad, Tal. Mulashi,
Dist. Pune.

Subject : Environment Clearance for Proposed residential cum commercial construction project S. No. 70/1 and S. No. 65/1/1B, Mouje Wakad, Tal. Mulashi, Dist. Pune by M/s. Akanksha Builders

Reference : Application no. SIA/MH/MIS/217615/2021

This has reference to your communication on the above mentioned subject. The proposal was considered by the SEAC-3 in its 126th meeting under screening category 8 (a) B2 as per EIA Notification, 2006 and recommend to SEIAA. Proposal then considered in 234th (Day-3) meeting of State Level Environment Impact Assessment Authority (SEIAA).

2. Brief Information of the project submitted by you is as below:-

1	Proposal Number	SIA/MH/MIS/217615/2021	
2	Name of Project	“Proposed Residential cum Commercial Construction Project” located at S. No. 70/1 and S. No. 65/1/1B, Mouje Wakad, Tal. - Mulshi, Dist-Pune.	
3	Project category	8 (a) of EIA Notification 2006- B2 Type – Building & Construction Project	
4	Type of Institution	Joint Venture Project	
5	Project Proponent	Name	Mr. Nihal Shaikh (Partner)
		Regd. Office address	The Pentagon Building, office no. 213, off Pune - Satara Road, Near Hotel Panchami, Parvati Dist. Pune
		Contact number	9850094796, 020-24222844/55
		e-mail	wakad70@gmail.com
6	EMP Consultant	Accredited by NABET vide accreditation no.: NABET/EIA/1922/RA 0199 valid till 24 th September 2022 (the scope of consultancy is limited only to preparation of Environmental Management Plan as per EIA amendment notification 3 rd March 2016)	
7	Applied for	Fresh EC	
8	Details of previous EC	Not Applicable	
9	Location of the project	S. No. 70/1 and S. No. 65/1/1B, at Mouje Wakad, Tal. - Mulshi, Dist-Pune.	

10	Latitude and Longitude	Latitude: 18°35'45.90"N Longitude: 73°44'38.01"E			
11	Total Plot Area (m ²)	12,491.72			
12	Deductions (m ²)	2019.11			
13	Net Plot area (m ²)	10472.61			
14	Proposed FSI area (m ²)	40258.87			
15	Proposed Non-FSI area (m ²)	24241.13			
16	Proposed TBUA (m ²)	64500.00			
17	TBUA (m ²) approved by Planning Authority till date	TBUA (FSI+Non FSI) approved by PCMC as per IOD letter no. BP/EC/Wakad/09/2021 dated 08.10.2021 is 66452.11 m ²			
18	Ground coverage (m ²) & %	3240.92 m ² (25.94)%			
19	Total Project Cost (Rs.)	97 Cr			
20	CER as per MoEF & CC circular dated 01/05/2018	CER Activities will be done as and if applicable			
21	Details of Building Configuration: <Please use following legends: Floor = F , Parking = Pk, Podium = Po, Stilt =St, Lower Ground = LG, Upper Ground = UG, Basement = B, Shops = Sh>				
	Previous EC / Existing Building		Proposed Configuration		
	Building Name	Configuration	Height (m)	Building Name	Configuration
	-	-	-	A Wing	B + G + Po + 16 F
	-	-	-	B Wing	B + G + Po + 16 F
	-	-	-	C Wing	B + G + Po + 16 F
	-	-	-	C Wing (LIG)	B + G + Po + 16 F
	-	-	-	Commercial Building Wing D	G + 11
22	Total number of tenements	391 Flats and 11 Offices			
23	Water Budget	Dry Season (CMD)		Wet Season (CMD)	
		Fresh Water	192	Fresh Water	192
		Recycled (Flushing + Gardening)	113	Recycled	101
		Swimming Pool	-	Swimming Pool	-
		Flushing	101	Flushing	101
		Total	305	Total	293
	Waste water generation	264	Waste water generation	264	
24	Water Storage Capacity for Firefighting / UGT	UGT Tank	Domestic (m ³)	Flushing (m ³)	Fire (m ³)
		OHT	192	101	100
		UGT	292	70	650

25	Source of water	Pimpri Chinchwad Municipal Corporation		
26	Rainwater Harvesting (RWH)	Level of the Ground water table	Pre-Monsoon: 6.5 mt Post Monsoon: 3.5 mt	
		Size and no of RWH tank(s) and Quantity	N.A.	
		Quantity and size of recharge pits	Total 4 Nos. (2 for Roof Top & 2 for Surface Run Off) Size: 2.0 m × 2.0 m × 2.0 m	
		Details of UGT tanks if any	NA	
27	Sewage and Wastewater	Sewage generation in CMD	264	
		STP technology	MBBR	
		Capacity of STP (CMD)	STP 1- 250 KLD (Residential) STP 2- 30 KLD (Commercial)	
28	Solid Waste Management during Construction Phase	Type	Quantity (kg/d)	Treatment / disposal
		Dry waste:	18 Kg /day	Handed over to authorized agency
		Wet waste:	27 Kg /day	
		Construction Waste:	2 m ³ /day	Reuse for road construction & refilling
29	Solid Waste Management during Operation Phase	Type	Quantity (kg/d)	Treatment / disposal
		Dry waste	487	Treatment – Segregation at source only, Disposal - Through authorized vendor (SWaCH, Pune)
		Wet waste	651	Treatment – OWC machine Disposal – Used as a manure
		Hazardous waste	N.A.	N.A.
		Biomedical waste	Not Quantified yet	Authorized Vendor
		E-Waste	1615 Kg/Year	Handed over to Authorized Agency
		STP Sludge (dry)	17 Kg/day	Used as manure
30	Green Belt Development	Total RG area (m ²)	Proposed Open Space Area: 1050.00 m ² Proposed Green Belt: 1634.98 m ² Total Landscape area: 2682.24 m ²	
		Existing trees on plot	4	
		Number of trees to be planted	152	
		Number of trees to be cut	Nil	
		Number of trees to be transplanted	NIL	
31	Power Requirement	Source of power supply	MSEDCL	
		During Construction Phase (Demand Load)	45 kW	
		During Operation phase (Connected load)	3010 KW, 3345 KVA	
		During Operation phase (Demand load)	1627 KW, 1808 KVA	
		Transformer	630 kVA X 2 Nos 315 kVA X 1 Nos	
		DG set	225 KVA x 2 No	
		Fuel used	HSD	
32	Details of	<ul style="list-style-type: none"> ➤ Timer control external lighting 		

	Energy saving	<ul style="list-style-type: none"> ➤ Natural light during day time and timers during night time in parking area lighting ➤ Maximum use of daylight in tenements area by providing appropriate window sizing ➤ Energy efficient lighting fixtures (LED lights) to all Buildings ➤ Saving in Energy Consumption is 22 % ➤ Use of LED lamps in all public/ common areas. ➤ Solar water heating for all tenements ➤ Separate energy meter for all pollution control devices ➤ Electricity generation through solar PV Panels ➤ Use of Energy efficient motors 				
33	Environmental Management plan budget during Construction phase	No.	Details		Cost	
		1	Erosion Control: Dust Suppression measures & barricading		Rs. 5 Lakh	
		2	Site Safety: Nets, Barricades		Rs. 2 Lakh	
		3	Site Sanitation: Public Toilets		Rs. 2 Lakh	
		4	Disinfection & health checkup		Rs. 2 Lakh	
		5	Environmental Monitoring: STP, OWC		Rs. 1.20 Lakh	
		6	Total		Rs. 12.20 Lakh	
34	Environmental Management plan Budget during Operation phase	Component	Details		Capital Cost (Lakh)	O&M Cost (Lakh/Y)
		Sewage treatment	STP (including external drainage connection)		96.00	20.00
		Storm water networking	Storm water networking		33.00	2.00
		RWH	Rain Water Harvesting		15.00	1.00
		Solid Waste	Solid waste Management		14.00	2.00
		Green Belt Development	Landscape		88.00	2.0
		Swimming Pool	Swimming Pool		20.00	2.00
		Energy Saving Measures	Solar water heater, solar PV. Energy efficient Equipments		117.00	2.00
		Environmental Monitoring			2.00	3.00
		Safety training & awareness			5.00	1.00
		EMP Cost			390.00	35.00
		Disaster Management Cost			150.00	4.00
Grand Total (EMP + DMP)			540.00	39.00		
35	Traffic Management	Type	Required as per DCR		Actual Provided	Area per parking (m2)
		4-Wheeler	302		327	12.5
		2-Wheeler	1320		1328	2.00
		Bicycles	-		-	0.7

3. Proposal is a new construction project. Proposal has been considered by SEIAA in its 234th (Day-3) meeting and decided to accord Environment Clearance to the said project under the provisions of Environment Impact Assessment Notification, 2006 subject to implantation of following terms and conditions-

Specific Conditions:

A. SEAC Conditions-

1. PP to submit the MoD NoC.
2. PP to submit the details of electricity generation through solar PV Panels.
3. PP to provide minimum 30% of total parking arrangement with electric charging facility by providing charging points at suitable places.

B. SEIAA Conditions-

1. PP to keep open space unpaved so as to ensure permeability of water. However, whenever paving is deemed necessary, PP to provide grass pavers of suitable types & strength to increase the water permeable area as well as to allow effective fire tender movement.
2. PP to achieve at least 5% of total energy requirement from solar/other renewable sources.
3. PP Shall comply with Standard EC conditions mentioned in the Office Memorandum issued by MoEF& CC vide F.No.22-34/2018-IA.III dt.04.01.2019.
4. SEIAA after deliberation decided to grant EC for – FSI-40258.87 m², Non-FSI-24241.13 m², Total BUA-64500.00 m². (Plan approval-BP/EC/Wakad/09/2021 dated 08.10.2021).

General Conditions:

a) Construction Phase :-

- I. The solid waste generated should be properly collected and segregated. Dry/inert solid waste should be disposed of to the approved sites for land filling after recovering recyclable material.
- II. Disposal of muck, Construction spoils, including bituminous material during construction phase should not create any adverse effect on the neighbouring communities and be disposed taking the necessary precautions for general safety and health aspects of people, only in the approved sites with the approval of competent authority.
- III. Any hazardous waste generated during construction phase should be disposed of as per applicable rules and norms with necessary approvals of the Maharashtra Pollution Control Board.
- IV. Adequate drinking water and sanitary facilities should be provided for construction workers at the site. Provision should be made for mobile toilets. The safe disposal of wastewater and solid wastes generated during the construction phase should be ensured.
- V. Arrangement shall be made that waste water and storm water do not get mixed.
- VI. Water demand during construction should be reduced by use of pre-mixed concrete, curing agents and other best practices.
- VII. The ground water level and its quality should be monitored regularly in consultation with Ground Water Authority.
- VIII. Permission to draw ground water for construction of basement if any shall be obtained from the competent Authority prior to construction/operation of the project.
- IX. Fixtures for showers, toilet flushing and drinking should be of low flow either by use of aerators or pressure reducing devices or sensor based control.

- X. The Energy Conservation Building code shall be strictly adhered to.
- XI. All the topsoil excavated during construction activities should be stored for use in horticulture / landscape development within the project site.
- XII. Additional soil for levelling of the proposed site shall be generated within the sites (to the extent possible) so that natural drainage system of the area is protected and improved.
- XIII. Soil and ground water samples will be tested to ascertain that there is no threat to ground water quality by leaching of heavy metals and other toxic contaminants.
- XIV. PP to strictly adhere to all the conditions mentioned in Maharashtra (Urban Areas) Protection and Preservation of Trees Act, 1975 as amended during the validity of Environment Clearance.
- XV. The diesel generator sets to be used during construction phase should be low sulphur diesel type and should conform to Environments (Protection) Rules prescribed for air and noise emission standards.
- XVI. PP to strictly adhere to all the conditions mentioned in Maharashtra (Urban Areas) Protection and Preservation of Trees Act, 1975 as amended during the validity of Environment Clearance.
- XVII. Vehicles hired for transportation of Raw material shall strictly comply the emission norms prescribed by Ministry of Road Transport & Highways Department. The vehicle shall be adequately covered to avoid spillage/leakages.
- XVIII. Ambient noise levels should conform to residential standards both during day and night. Incremental pollution loads on the ambient air and noise quality should be closely monitored during construction phase. Adequate measures should be made to reduce ambient air and noise level during construction phase, so as to conform to the stipulated standards by CPCB/MPCB.
- XIX. Diesel power generating sets proposed as source of backup power for elevators and common area illumination during construction phase should be of enclosed type and conform to rules made under the Environment (Protection) Act, 1986. The height of stack of DG sets should be equal to the height needed for the combined capacity of all proposed DG sets. Use low sulphur diesel is preferred. The location of the DG sets may be decided with in consultation with Maharashtra Pollution Control Board.
- XX. Regular supervision of the above and other measures for monitoring should be in place all through the construction phase, so as to avoid disturbance to the surroundings by a separate environment cell /designated person.

B) Operation phase:-

- I. a) The solid waste generated should be properly collected and segregated. b) Wet waste should be treated by Organic Waste Converter and treated waste (manure) should be utilized in the existing premises for gardening. And, no wet garbage will be disposed outside the premises. c) Dry/inert solid waste should be disposed of to the approved sites for land filling after recovering recyclable material.
- II. E-waste shall be disposed through Authorized vendor as per E-waste (Management and Handling) Rules, 2016.
- III. a) The installation of the Sewage Treatment Plant (STP) should be certified by an

- independent expert and a report in this regard should be submitted to the MPCB and Environment department before the project is commissioned for operation. Treated effluent emanating from STP shall be recycled/ reused to the maximum extent possible. Treatment of 100% grey water by decentralized treatment should be done. Necessary measures should be made to mitigate the odour problem from STP. b) PP to give 100 % treatment to sewage /Liquid waste and explore the possibility to recycle at least 50 % of water, Local authority should ensure this.
- IV. Project proponent shall ensure completion of STP, MSW disposal facility, green belt development prior to occupation of the buildings. As agreed during the SEIAA meeting, PP to explore possibility of utilizing excess treated water in the adjacent area for gardening before discharging it into sewer line No physical occupation or allotment will be given unless all above said environmental infrastructure is installed and made functional including water requirement.
 - V. The Occupancy Certificate shall be issued by the Local Planning Authority to the project only after ensuring sustained availability of drinking water, connectivity of sewer line to the project site and proper disposal of treated water as per environmental norms.
 - VI. Traffic congestion near the entry and exit points from the roads adjoining the proposed project site must be avoided. Parking should be fully internalized and no public space should be utilized.
 - VII. PP to provide adequate electric charging points for electric vehicles (EVs).
 - VIII. Green Belt Development shall be carried out considering CPCB guidelines including selection of plant species and in consultation with the local DFO/ Agriculture Dept.
 - IX. A separate environment management cell with qualified staff shall be set up for implementation of the stipulated environmental safeguards.
 - X. Separate funds shall be allocated for implementation of environmental protection measures/EMP along with item-wise breaks-up. These cost shall be included as part of the project cost. The funds earmarked for the environment protection measures shall not be diverted for other purposes.
 - XI. The project management shall advertise at least in two local newspapers widely circulated in the region around the project, one of which shall be in the Marathi language of the local concerned within seven days of issue of this letter, informing that the project has been accorded environmental clearance and copies of clearance letter are available with the Maharashtra Pollution Control Board and may also be seen at Website at <http://parivesh.nic.in>
 - XII. Project management should submit half yearly compliance reports in respect of the stipulated prior environment clearance terms and conditions in hard & soft copies to the MPCB & this department, on 1st June & 1st December of each calendar year.
 - XIII. A copy of the clearance letter shall be sent by proponent to the concerned Municipal Corporation and the local NGO, if any, from whom suggestions/representations, if any, were received while processing the proposal. The clearance letter shall also be put on the website of the Company by the proponent.
 - XIV. The proponent shall upload the status of compliance of the stipulated EC conditions, including results of monitored data on their website and shall update the same periodically. It shall simultaneously be sent to the Regional Office of MoEF, the respective Zonal Office of CPCB and the SPCB. The criteria pollutant levels namely;

SPM, RSPM. SO₂, NO_x (ambient levels as well as stack emissions) or critical sector parameters, indicated for the project shall be monitored and displayed at a convenient location near the main gate of the company in the public domain.

C) General EC Conditions:-

- I. PP has to strictly abide by the conditions stipulated by SEAC & SEIAA.
 - II. If applicable Consent for Establishment" shall be obtained from Maharashtra Pollution Control Board under Air and Water Act and a copy shall be submitted to the Environment department before start of any construction work at the site.
 - III. Under the provisions of Environment (Protection) Act, 1986, legal action shall be initiated against the project proponent if it was found that construction of the project has been started without obtaining environmental clearance.
 - IV. The project proponent shall also submit six monthly reports on the status of compliance of the stipulated EC conditions including results of monitored data (both in hard copies as well as by e-mail) to the respective Regional Office of MoEF, the respective Zonal Office of CPCB and the SPCB.
 - V. The environmental statement for each financial year ending 31st March in Form-V as is mandated to be submitted by the project proponent to the concerned State Pollution Control Board as prescribed under the Environment (Protection) Rules, 1986, as amended subsequently, shall also be put on the website of the company along with the status of compliance of EC conditions and shall also be sent to the respective Regional Offices of MoEF by e-mail.
 - VI. No further Expansion or modifications, other than mentioned in the EIA Notification, 2006 and its amendments, shall be carried out without prior approval of the SEIAA. In case of deviations or alterations in the project proposal from those submitted to SEIAA for clearance, a fresh reference shall be made to the SEIAA as applicable to assess the adequacy of conditions imposed and to add additional environmental protection measures required, if any.
 - VII. This environmental clearance is issued subject to obtaining NOC from Forestry & Wild life angle including clearance from the standing committee of the National Board for Wild life as if applicable & this environment clearance does not necessarily implies that Forestry & Wild life clearance granted to the project which will be considered separately on merit.
4. The environmental clearance is being issued without prejudice to the action initiated under EP Act or any court case pending in the court of law and it does not mean that project proponent has not violated any environmental laws in the past and whatever decision under EP Act or of the Hon'ble court will be binding on the project proponent. Hence this clearance does not give immunity to the project proponent in the case filed against him, if any or action initiated under EP Act.
5. This Environment Clearance is issued purely from an environment point of view without prejudice to any court cases and all other applicable permissions/ NOCs shall be obtained before starting proposed work at site.
6. In case of submission of false document and non-compliance of stipulated conditions, Authority/ Environment Department will revoke or suspend the Environment clearance without any intimation and initiate appropriate legal action under Environmental Protection Act, 1986.
7. Validity of Environment Clearance: The environmental clearance accorded shall be valid as per EIA Notification, 2006, amended from time to time.

8. The above stipulations would be enforced among others under the Water (Prevention and Control of Pollution) Act, 1974, the Air (Prevention and Control of Pollution) Act, 1981, the Environment (Protection) Act, 1986 and rules there under, Hazardous Wastes (Management and Handling) Rules, 1989 and its amendments, the public Liability Insurance Act, 1991 and its amendments.

9. Any appeal against this Environment clearance shall lie with the National Green Tribunal (Western Zone Bench, Pune), New Administrative Building, 1st Floor, D-Wing, Opposite Council Hall, Pune, if preferred, within 30 days as prescribed under Section 16 of the National Green Tribunal Act, 2010.

Manisha Patankar-Mhaiskar
(Member Secretary, SEIAA)
9/1/2022

Copy to:

1. Chairman, SEIAA, Mumbai.
2. Secretary, MoEF & CC, IA- Division MOEF & CC
3. Member Secretary, Maharashtra Pollution Control Board, Mumbai.
4. Regional Office MoEF & CC, Nagpur
5. District Collector, Pune.
6. Commissioner, Pune Municipal Corporation
7. Regional Officer, Maharashtra Pollution Control Board, Pune.

Signature Not Verified

Digitally signed by Manisha
Patankar Mhaiska
Member Secretary

Date: 1/10/2022 12:23:00 PM

**Annexure IV: Soil and Ground Water
Analysis Reports**

TEST REPORT

Sample ID : S/10/22/0340	Report No. S/10/22/0340	Report Date	01/11/2022
Name and address of Customer	Akanksha Builders Proposed Residential cum Commercial Construction Project S. No. 70/1 and S. No. 65/1/1B, At Nouje Wakad, Tal. Mulshi, Dist. Pune, Maharashtra		
Sampling done by	Laboratory	Sample Description / Type	Soil
Sample Location	Project site	Date - Sampling	21/10/2022
Sample Quantity / Packing	1 kg x 1 no. paper bag	Date - Receipt of Sample	22/10/2022
Sampling Procedure	AEC/SAM/37	Date - Start of Analysis	22/10/2022
Order Reference	Letter dated 17.10.2022	Date - Completion of Analysis	31/10/2022

Sr. No.	Parameter	Result	Unit	Method
Chemical Testing; Group: Pollution & Environment				
1	pH (1:5 suspension)	7.38	-	FAO, Sec. III, I, Page no.65
2	Moisture Content	24.1	% by Weight	Dept. of Agriculture & Cooperation, Ministry of Agriculture, Govt. of India, Jan 2011
3	Water Holding Capacity	19.5	%	AEC/C/SAP/S-18
4	Cation Exchange Capacity	37	meq/100g	FAO, Sec. III, 7-2, Page no.104
5	Total Nitrogen (as N)	74.6	mg/kg	FAO, Sec III, 4, Page No. 78
6	Total Potassium (as K)	763	mg/kg	USEPA/SW 846/6010 C
7	Sodium (as Na)	2901	mg/kg	USEPA/SW 846/6010 C
8	Copper (as Cu)	60.8	mg/kg	USEPA/SW 846/6010 C
9	Cadmium (as Cd)	1.09	mg/kg	USEPA/SW 846/6010 C
10	Lead (as Pb)	2.66	mg/kg	USEPA/SW846/6010 C
11	Nickel (as Ni)	38.9	mg/kg	USEPA/SW 846/6010 C
12	Zinc (as Zn)	32.6	mg/kg	USEPA/SW 846/6010 C
13	Boron (as B)	34.7	mg/kg	USEPA/SW 846/6010 C
14	Chloride (as Cl)	104	mg/kg	AEC/C/SAP/S-7
15	Sulphate (as SO ₄)	394	mg/kg	USEPA/SW 846/9038

Note: All results are on air dry basis.

FAO: Food & Agriculture Organization, United Nations.

Sample ID S/10/22/0340 bears two Test Reports - S/10/22/0340 and S/10/22/0340N

Ninad Soundankar
Technical Manager (Chemical)
Reviewed & Authorised by

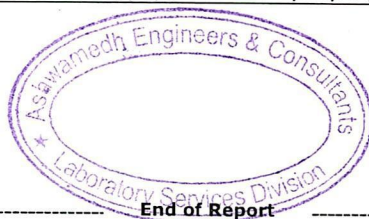

End of Report

Note:

1. The result listed refer only to the tested sample(s) and applicable parameter(s).
2. This report is not to be reproduced except in full, without written approval of the laboratory.
3. In case sampling is not done by laboratory, the results apply to the sample as received.
4. There are no additions to, deviations or exclusions from the method.



TEST REPORT

Sample ID : S/10/22/0340	Report No. S/10/22/0340N	Report Date	01/11/2022
Name and address of Customer	Akanksha Builders Proposed Residential cum Commercial Construction Project S. No. 70/1 and S. No. 65/1/1B, At Nouje Wakad, Tal. Mulshi, Dist. Pune, Maharashtra		
Sampling done by	Laboratory	Sample Description / Type	Soil
Sample Location	Project site	Date - Sampling	21/10/2022
Sample Quantity / Packing	1 kg x 1 no. paper bag	Date - Receipt of Sample	22/10/2022
Sampling Procedure	AEC/SAM/37	Date - Start of Analysis	22/10/2022
Order Reference	Letter dated 17.10.2022	Date - Completion of Analysis	31/10/2022

Sr. No.	Parameter	Result	Unit	Method
Chemical Testing; Group: Pollution & Environment				
1	Calcium (as Ca)	1.30	%	USEPA/SW 846/6010 C
2	Mercury (as Hg)	0.047	mg/kg	USEPA/SW 846/6010 C

Note: All results are on air dry basis.

FAO: Food & Agriculture Organization, United Nations.

Sample ID S/10/22/0340 bears two Test Reports - S/10/22/0340 and S/10/22/0340N



Ninad Soundankar
Technical Manager (Chemical)
Reviewed & Authorised by

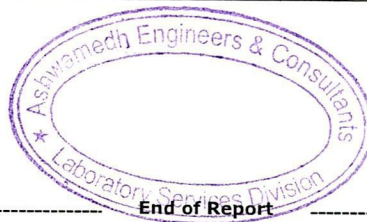

End of Report

Note:

1. The result listed refer only to the tested sample(s) and applicable parameter(s).
2. This report is not to be reproduced except in full, without written approval of the laboratory.
3. In case sampling is not done by laboratory, the results apply to the sample as received.
4. There are no additions to, deviations or exclusions from the method.



ULR-TC550922000016575F

TEST REPORT

Sample ID : W/10/22/0439	Report No. W/10/22/0439	Report Date	02/11/2022
Name and address of Customer	Akanksha Builders Proposed Residential cum Commercial Construction Project S. No. 70/1 and S. No. 65/1/1B, At Nouje Wakad, Tal. Mulshi, Dist. Pune, Maharashtra		
Sampling done by	Laboratory	Sample Description / Type	Water (Drinking Water)
Sampling Location	Near Site Office - 20 Litre Jar	Date - Sampling	21/10/2022
Sample Quantity / Packing	2 L x 1 no. plastic can	Date - Receipt of Sample	22/10/2022
Sampling Procedure	IS 3025 (Part 1):1987, Amds.1 & APHA, 23rd Ed.,2017,1060 B,1-40	Date - Start of Analysis	22/10/2022
Order Reference	Letter Reference dated 17.10.2022	Date - Completion of Analysis	02/11/2022

Sr.No.	Parameter	Result	Acceptable Limit as per IS 10500:2012	Unit	Method
Chemical Testing; Group: Water, Residues in Water					
Physical & Chemical Parameters					
1	pH value	6.89	6.5-8.5	-	IS 3025 (Part II):1983
2	Turbidity	BLQ (LOQ:0.2)	Max. 1	NTU	IS 3025 (Part 10):1984
3	Electrical Conductivity (at 25°C)	145	Not specified	µmho/cm	IS 3025 (Part 14):1984
4	Total Dissolved Solids	82	Max.500	mg/L	IS 3025 (Part 16): 1984
5	Ammonia (as total ammonia-N)	BLQ (LOQ:0.1)	Max.0.5	mg/L	APHA, 23rd Ed., 4500 NH3, F, 4 -119
6	Calcium (as Ca)	8.81	Max. 75	mg/L	IS 3025 (Part 40): 1991
7	Chloride (as Cl)	14.5	Max. 250	mg/L	IS 3025 (Part 32):1988
8	Fluoride (as F)	0.1	Max.1.0	mg/L	IS 3025 (Part 60):2008
9	Iron (as Fe)	BLQ (LOQ:0.06)	Max.1.0	mg/L	IS 3025 (Part 2):2019/ISO 11885:2007
10	Magnesium (as Mg)	4.37	Max. 30	mg/L	IS 3025 (Part 46): 1994
11	Nitrate (as NO ₃)	1.98	Max.45	mg/L	APHA, 23rd Ed., 4500-NO3 B-4-127
12	Sulphate (as SO ₄)	4.9	Max. 200	mg/L	IS 3025 (Part 24): 1986
13	Total Alkalinity (as CaCO ₃)	35	Max. 200	mg/L	IS 3025(Part 23):1986
14	Phenolphthalein Alkalinity (as CaCO ₃)	BLQ (LOQ:0.5)	Not specified	mg/L	IS 3025(Part 23): 1986
15	Total Hardness (as CaCO ₃)	40	Max. 200	mg/L	IS 3025 (Part 21): 1983
16	Calcium Hardness (as CaCO ₃)	22	Not specified	mg/L	IS 3025 (Part 40): 2004
17	Total Phosphate (as P)	BLQ (LOQ:0.1)	Not specified	mg/L	APHA, 23rd Ed., 4500 P.E, 4-164
18	Sodium (as Na)	6.7	Not specified	mg/L	IS 3025 (Part 45): 1993
19	Potassium (as K)	0.86	Not specified	mg/L	IS 3025 (Part 45): 1993
20	Lead (as Pb)	BLQ (LOQ:0.008)	Max. 0.01	mg/L	IS 3025 (Part 2):2019/ISO 11885:2007

BLQ: Below Limit of Quantification, LOQ: Limit of Quantification

Remark: The analysed Water Sample results conform with Acceptable Limit (wherever specified) as per IS 10500:2012 [With Amendment No.1,2,3 and 4] Standard with respect to the parameters tested, without applying measurement uncertainty.

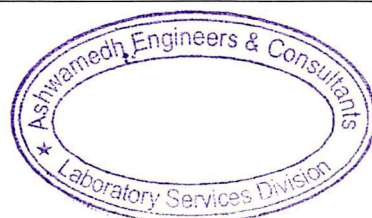

B. Shewale
Kavita Shewale
Section In-Charge (Chemical)
Reviewed & Authorised by

ULR-TC550922000016575F

Sample ID : W/10/22/0439	Report No. W/10/22/0439	Report Date	02/11/2022
--------------------------	-------------------------	-------------	------------

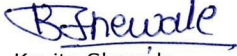

Kavita Shewale
Section In-charge (Chemical)
Reviewed & Authorised by



Note:

1. The result listed refer only to the tested sample(s) and applicable parameter(s).
2. This report is not to be reproduced except in full, without written approval of the laboratory.
3. In case sampling is not done by laboratory, the results apply to the sample as received.
4. There are no additions to, deviations or exclusions from the method.
5. Statement of conformity is based on the decision rule applied.



Annexure V: Ambient Air & Noise Reports

AMBIENT AIR QUALITY MONITORING REPORT

Sample ID : AA/10/22/0394	Report No. AA/10/22/0394	Report Date	01/11/2022
Name and address of Customer	Akanksha Builders Proposed Residential cum Commercial Construction Project S. No. 70/1 and S. No. 65/1/1B, At Nouje Wakad, Tal. Mulshi, Dist. Pune, Maharashtra		
Sampling done by	Laboratory	Sample Description / Type	Ambient Air
Sampling Location	Near Main Gate	Date - Sampling	20/10/2022 to 21/10/2022
Sample Quantity / Packing	PM ₁₀ : Bap, Metals: 1 x 3 no. filter paper PM _{2.5} : 1 x 1 no. filter paper SO ₂ , NO ₂ : 30 ml x 6 no. plastic bottle each NH ₃ : 10 ml x 24 no. plastic bottle Ozone: 10 ml x 1 no. plastic bottle C ₆ H ₆ : 1 x 6 no. charcoal tubes CO: 1 x 1 no. bladder	Date - Receipt of Sample	22/10/2022
Sampling Procedure	As per method reference	Date - Start of Analysis	22/10/2022
Order Reference	Letter dated 17.10.2022	Date - Completion of Analysis	31/10/2022

Meteorological Data / Environmental Conditions

Average Wind Velocity 7.5 km/h	Wind Direction E-W	Relative Humidity (Max./Min.): 76/72%	Temperature (Max./Min.): 26/23°C	Duration of Survey 24 h
-----------------------------------	-----------------------	--	-------------------------------------	----------------------------

Parameter	Result	NAAQS# 2009	Unit	Method
Chemical Testing; Group: Atmospheric Pollution				
Sulphur Dioxide (SO ₂)	BLQ (LOQ:4)	80	µg/m ³	IS 5182 (Part 2): 2001
Nitrogen Dioxide (NO ₂)	7.18	80	µg/m ³	IS 5182 (Part 6): 2006
Particulate Matter (size less than 10 µm) or PM ₁₀	50	100	µg/m ³	IS 5182 (Part 23): 2006
Particulate Matter (size less than 2.5µm) or PM _{2.5}	11	60	µg/m ³	CPCB Guideline, Volume I, 36/2012-13, Page No.15:2013
Ozone (O ₃)	BLQ (LOQ:19.6)	180	µg/m ³	Methods of Air Sampling and Analysis (AWMA), 3rd Ed., Method 411, Page no. 403 :1988
Lead (as Pb)	BLQ (LOQ:0.02)	1	µg/m ³	EPA/625/R-96/010 a Compendium Method 10-3.1 & 3.4
Carbon Monoxide (CO)	1.79	4	mg/m ³	CPCB Guidelines, Volume II, 37/2012-13, Page no.16: 2013
Ammonia (NH ₃)	BLQ (LOQ:20)	400	µg/m ³	CPCB Guidelines, Volume I, 36/2012-13, Page No.35: 2013
Benzene (C ₆ H ₆)	2.71	5	µg/m ³	IS 5182 (Part II) : 2006
Benzo (a) pyrene (BaP) Particulate Phase only	BLQ (LOQ:0.2)	1	ng/m ³	IS 5182 (Part 12): 2004
Arsenic (as As)	BLQ (LOQ:0.3)	6	ng/m ³	EPA/625/R-96/010 a Compendium Method 10-3.1 & 3.4
Nickel (as Ni)	BLQ (LOQ:3)	20	ng/m ³	EPA/625/R-96/010 a Compendium Method 10-3.1 & 3.4

BLQ: Below Limit of Quantification, LOQ: Limit of Quantification

TWA : Time Weighted Average

: NAAQS (National Ambient Air Quality Standards (Industrial, Residential, Rural and other Area) specified as: 24 hours TWA in case of Sulphur Dioxide, Nitrogen Dioxide, PM₁₀, PM_{2.5}, Lead and Ammonia, 1 hour TWA in case of Carbon Monoxide and Ozone, Annual TWA in case of Benzene, Benzo (a) Pyrene, Arsenic and Nickel.

B. Shewale

Kavina Shewale
Section In-Charge (Chemical)
Reviewed & Authorised by

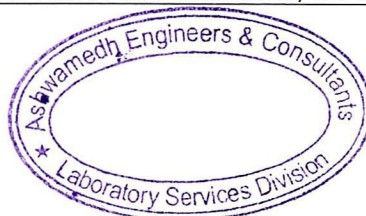

Sample ID : AA/10/22/0394	Report No. AA/10/22/0394	Report Date	01/11/2022
---------------------------	--------------------------	-------------	------------

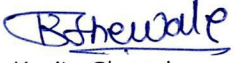

Kavita Shewale
Section In-charge (Chemical)
Reviewed & Authorised by



Note:

1. The result listed refer only to the tested sample(s) and applicable parameter(s).
2. This report is not to be reproduced except in full, without written approval of the laboratory.
3. In case sampling is not done by laboratory, the results apply to the sample as received.
4. There are no additions to, deviations or exclusions from the method.





NOISE LEVEL MEASUREMENT REPORT

Sample ID: N/10/22/0397	Report No.: N/10/22/0397	Report Date	25/10/2022
Name and Address of Customer	Akanksha Builders Proposed Residential cum Commercial Construction Project S. No. 70/1 and S. No. 65/1/1B, At Nouje Wakad, Tal. Mulshi, Dist. Pune		
Monitoring Done By	Laboratory	Sample Description /Type	Ambient Noise
Order Reference	As per Letter Dated 17.10.2022	Date of Monitoring	20/10/2022

Chemical Testing; Group: Atmospheric Pollution

Location	Time (h)	Results	Results	Method
		Noise Level dB (A) Fast Response	Noise Level dB (A) Slow Response	
Near Main Gate	09:15	53.6	52.8	CPCB Protocol for Ambient Level Noise Monitoring, July AEC/C/SAP/SAM/356 36, Issue no.:4, Issue date 01.04.2018
	22:10	42.9	42.1	

Limits

As Per the Noise Pollution (Regulation & Control) Rules, 2000 (Rules 3 (1) and 4(1))

Area Type	Limits in dB (A) weighted scale	
	Day (6 a.m. to 10 p.m.)	Night (10 p.m. to 6 a.m.)
Residential	55	45

Ninad Soundankar
Technical Manager (Chemical)
Reviewed & Authorised by

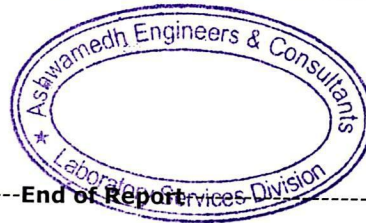

End of Report

Note:

1. The result listed refers only to the tested sample(s) and applicable parameter(s).
2. This report is not to be reproduced except in full, without written approval of the laboratory.
3. In case sampling is not done by laboratory, the results apply to the sample as received.
4. There are no additions to, deviation or exclusions from the method.



NOISE LEVEL MEASUREMENT REPORT

Sample ID: N/10/22/3315	Report No.: N/10/22/3315N	Report Date	25/10/2022
Name and Address of Customer	Akanksha Builders Proposed Residential cum Commercial Construction Project S. No. 70/1 and S. No. 65/1/1B, At Nouje Wakad, Tal. Mulshi, Dist. Pune		
Monitoring Done By	Laboratory	Sample Description /Type	DG Noise
Order Reference	As per Letter Dated 17.10.2022	Date-Monitoring	20/10/2022

Chemical Testing; Group: Atmospheric Pollution

Sr. No.	Location	Time (h)	Sound Level dB (A) Fast Response				Difference
			A	Inside	B	Outside	
1.	DG SET 125 KVA	09:45	A1	94.2	A2	69.1	25.1
		09:50	B1	97.1	B2	72.1	25
		10:00	C1	98.1	C2	73.1	25
		10:05	D1	95.6	D2	70.6	25
			Average	96.2	Average	71.2	25

Note: Standards as per MPCB Consent Condition 25 dB (A) insertion Loss.

[Signature]

Ninad Soundankar
Technical Manager (Chemical)
Reviewed & Authorised by

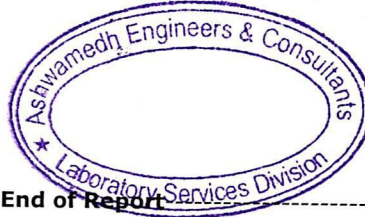

End of Report

Note:

1. The result listed refers only to the tested sample(s) and applicable parameter(s).
2. This report is not to be reproduced except in full, without written approval of the laboratory.
3. In case sampling is not done by laboratory, the results apply to the sample as received.
4. There are no additions to, deviation or exclusions from the method.





NOISE LEVEL MEASUREMENT REPORT

Sample ID: N/10/22/3316	Report No.: N/10/22/3316N	Report Date	25/10/2022
Name and Address of Customer	Akanksha Builders Proposed Residential cum Commercial Construction Project S. No. 70/1 and S. No. 65/1/1B, At Nouje Wakad, Tal. Mulshi, Dist. Pune		
Monitoring Done By	Laboratory	Sample Description /Type	DG Noise
Order Reference	As per Letter Dated 17.10.2022	Date-Monitoring	20/10/2022

Chemical Testing; Group: Atmospheric Pollution

Sr. No.	Location	Time (h)	Sound Level dB (A) Fast Response				Difference
			A	Inside	B	Outside	
1.	DG SET 32 KVA	10:10	A1	94.2	A2	69.2	25
		10:12	B1	93.5	B2	68.2	25.3
		10:15	C1	92.4	C2	67.3	25.1
		10:20	D1	91.3	D2	66.3	25
			Average	92.8	Average	67.7	25.1

Note: Standards as per MPCB Consent Condition 25 dB (A) insertion Loss.

Ninad Soundankar
Technical Manager (Chemical)
Reviewed & Authorised by

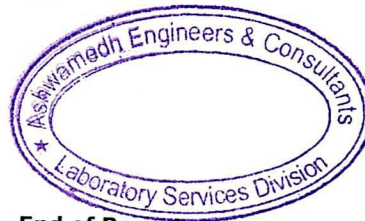

-----End of Report-----

Note:

1. The result listed refers only to the tested sample(s) and applicable parameter(s).
2. This report is not to be reproduced except in full, without written approval of the laboratory.
3. In case sampling is not done by laboratory, the results apply to the sample as received.
4. There are no additions to, deviation or exclusions from the method.



Annexure VI: Advertisement

शुक्रवार 21/10/22

शाहू सहकारी बँक लि. पुणे

प्रांचालय : ५३७ शाहू कॉम्प्लेक्स गिवाजी रोड शुक्रवार पेठ पुणे. ४११००२
 ३५३८५ / २४६६६१० सिंहगड रोड शाखा. २४३४६५८० / २४३४६५१०

174/ /2022-23

DATE-18/10/2022

IV रूल (८(१)) स्थावर ताबा नोटिस

आय ऑफ फायनान्शियल असेट्स अॅण्ड एन्फोरमेंट ऑफ सिक्युरिटी इंटरस्ट अॅक्ट कायदयानुसार खालील कर्जदार यांना नोटीस काढण्यात आलेली आहे.

शु. सहकारी बँक लि., पुणे ची मुख्य कचेरी येथील प्राधिकृत अधिकारी यांनी दि. १७/१०/२०२२ रोजी ऑफ फायनान्शियल असेट्स अॅण्ड एन्फोरमेंट ऑफ सिक्युरिटी इंटरस्ट अॅक्ट २००२ (१) श्री. राजापुणे हर्षद यशवंत २) श्री. राजापुणे यशवंत रामभाऊ व जामिनदार श्री. गुजर उमेश अंकुश व इतर यांच्यावर मागणी नोटीस दि. १७/१०/२०२२ रोजी कर्जदार व जामिनदार रजिस्टर ए. डी. ने बजविण्यात आली. ती मागणी नोटीस या मागणी नोटीसीप्रमाणे कर्जदाराला बँकेला परतफेड करावयाची रक्कम रुपये अठरा लाख एकोणशे हजार आठशे सत्तावीस रुपये पन्नास पैसे) दिनांक प्रसुन ती तुम्ही ६० दिवसांच्या आत बँकेला परतफेड करण्यात अपयशी ठरला आहात. जे रक्कम रुपये १०,०००/- कर्जखाती भरणा केला आहे. दिनांक १०/१०/२०२२ १.५० /- (अक्षरी एकोणीस लाख अकरा हजार पाचशे एकाहत्तर रुपये पन्नास पैसे) मील कालावधीपर्यंतचे व्याज, दंड, व्याज, खर्च व इतर अशी एकूण रक्कम कर्ज खाते सिंहगड रोड शाखा. वर उल्लेख केलेले खाते रिझर्व्ह बँकेच्या मार्गदर्शक तत्वानुसार व एन. पी. ए. म्हणून दिनांक १०/०६/२०२२ रोजी वर्गीकरण करण्यात आलेले आहे. सदर ठरल्यामुळे ही नोटीस कर्जदार, जामिनदार व मॉरगेजर व लोकांना कलम १३ (४) च्या तीकात्मक) ताबा दि. १८/१०/२०२२ रोजी घेतला आहे. कर्जदार, सहकर्जदार, यत्तिकरित्या व सामुहिकरित्या प्रसिध्द करण्यात येते कि, संबंधित राजर्षि शाहू सहकारी संबंधित कुठलाही व्यवहार करू नयेत. संबंधित बोजा असलेल्या मालमत्तेशी होणारे लि पुणे (सिंहगड रोड) शाखेला आज अखेर दि. १०/१०/२०२२ रोजी रु. १० लाख अकरा हजार पाचशे एकाहत्तर रुपये पन्नास पैसे रुपये) व पुढील होणारे ला जबाबदार असेल. कर्जदार, सहकर्जदार, जामिनदार व मॉरगेजर यांना कळविण्यात १७.१०/- (अक्षरी रक्कम एकोणीस लाख अकरा हजार पाचशे एकाहत्तर रुपये पन्नास त्रान्दारे प्रसिध्द केल्याप्रमाणे ३० दिवसांच्या आत भरली नाही तर दि सिक्युरिटीयज्ञेशन त असेट्स अॅण्ड एन्फोरमेंट ऑफ सिक्युरिटी इंटरस्ट अॅक्ट २००२ कायद्यांतर्गत गिद्दारे, ऑक्शन पद्धतीद्वारे, प्राधिकृत अधिकारी स्थावर मालमत्तेची विक्री करू शकतात.

इतर मालमत्तेचा तपशील - परिशील क्र. १

१) श्री. विनायक अपार्टमेंट फ्लॅट नं. १०१ ५८० चौ. फूट ५३.९० चौ.मी व फ्लॅट नं. १०३ ला कात्रज तालुका हवेली पुणे ४११०४६ परिशिमा - पूर्व - १५ फूट अंतर्गत रस्ता, क्षिण-नामदेव पवार यांची मालमत्ता, उत्तर-किरण गुजर यांची मालमत्ता

स्वाक्षरी
(प्राधिकृत अधिकारी)

राजर्षि शाहू सहकारी बँक लि. पुणे
(मुख्य कार्यालय)

बारामती शाखा: शॉप नं. ४,५,६, अवधूत प्लाझा, भिगवण रोड, बारामती, जिल्हा पुणे, बारामती, महाराष्ट्र-४१३१०२
 ईमेल : baramati@unionbankofindia.com

[रूल ८(१)] ताबा नोटीस

(फक्त स्थावर मालमत्तांकरिता)

आय ऑफ इंडिया, बारामती शाखेचे अधिकृत अधिकारी यांनी दि सिक्युरिटीयज्ञेशन अॅण्ड एन्फोरमेंट ऑफ सिक्युरिटी इंटरस्ट (दुसरा) अॅक्ट २००२ (२००२ चा ५४ टी इंटरस्ट (एन्फोरमेंट) रूल्स २००२ च्या रूल ३ अंतर्गत प्राप्त अधिकारांचा वापर करून त्यांच्या नावासमोर नमूद केलेल्या तारखाना मागणी नोटीस बजावली होती की, त्यांनी केलेली बँकेला येणे असलेली रक्कम आणि त्यावरील व्याज अशी सर्व रक्कम सदर नोटीस त परत करावी.

यामुळे कर्जदार तसेच सर्वसाधारण जनता यांना नोटीस देण्यात येते की, खाली सही करणारे सेक्शन १३ आणि सिक्युरिटी इंटरस्ट एन्फोरमेंट रूल्स २००२ च्या रूल ८ अंतर्गत प्राप्त खाली नमूद केलेल्या तारखाना ताबा घेतला आहे.

ता यांना सावध करण्यात येते की, त्यांनी सदर मालमत्तांसंदर्भात कोणत्याही प्रकारचा तो युनियन बँक ऑफ इंडिया, बारामती शाखा यांना खाली नमूद केलेली येणे रक्कम ल.

लेमये कर्जदाराचे सदर कायद्याच्या लक्ष सेक्शन १३(८) अंतर्गत तरतुदीकडे वेधून घेतले जात आहे.

नावे	येणे बाकी रक्कम	मागणी नोटीसीची तारीख ताबा घेतल्याची तारीख
रु. ११,३७,३६३.२०/- (रुपये अकरा लाख सदतीस हजार तीनशे त्रेसष्ट आणि पैसे वीस फक्त) आणि त्यावरील व्याज		२२/०४/२०२२ १९/१०/२०२२

०२ चा सर्वसामाईक भाग, चर्टई क्षेत्रफळ ५३.३५ चौ.मी. म्हणजेच ५७४.०० चौ.फू. आणि चौ.मी. म्हणजेच ०.६५१ चौ.फू. तसूच मजला गुरुप्रसाद रेसिडेन्सी एनए ब्लॉक नं. २४ वर

१६ लोकसत्ता

WWW.LOKSATTA.COM

पुणे, शुक्रवार, २१ ऑक्टोबर २०२२

जाहीर नोटीस

तमान जनतेस सुचित करण्यात येते कि आकांक्षा बिल्डर्स पुणे यांच्या स नं.७०/१ व ६५/१/१ व मोजे वाकड ता. मुळशी जि. पुणे येथील रहिवासी आणि व्यावसायिक गृहप्रकल्पास राज्य शासनाच्या पर्यावरण आघात मूल्यांकन प्राधिकरण, महाराष्ट्र यांच्या कडून EC222038MH158171 पर्यावरण विषयक परवानगी मिळाली आहे. हि परवानगी पर्यावरण आघात मूल्यांकन अधिसूचना २००६ नुसार देण्यात आलेली आहे. सदर परवानगीच्या प्रती महाराष्ट्र प्रदूषण नियंत्रण मंडळ येथे उपलब्ध असून पर्यावरण विभाग महाराष्ट्र शासन यांचा संकेत स्थळावर <http://parivesh.nic.in> उपलब्ध आहेत.

आयसीआयसीआय होम फायनान्स कंपनी लिमिटेड

नोंदणीकृत कार्यालय: आयसीआयसीआय बँक टॉवर्स, बान्द्रा-कुर्ला कॉम्प्लेक्स, मुंबई-४०० ०५१.
 कॉपोरेट कार्यालय: आयसीआयसीआय एचएफसी टॉवर, अंधेरी-कुर्ला रोड, अंधेरी (पूर्व), मुंबई - ४०००५९.

सुवर्ण लिलाव सूचना

याद्वारे सर्व लोकांना सूचित करण्यात येते की आयसीआयसीआय होम फायनान्स कंपनी लिमिटेड (आयसीआयसीआय एचएफसी) यांनी थकबाकी झालेल्या किंवा ना भरलेल्या किंवा माजिनचा भंग करणाऱ्या ग्राहकांच्या खालील खात्यांमध्ये तारण ठेवलेल्या सोन्याच्या दागिन्यांचा लिलाव करण्याचे ठरविले आहे. याद्वारे कर्जदार / सह-कर्जदार आणि सर्व लोकांना सूचित करण्यात येते की लिलावाच्या दिनांकापर्यंत (खाली नमूद) थकबाकी रकमेचा त्यावरील पुढील व्याज अधिक सर्व शुल्क व अनुबंधीक खर्च इ. चा भरणे करावे.

ज्या कर्जदार / सह-कर्जदारांना आपले दामिने सोडवून घेण्याची इच्छा आहे त्यांनी आपले दामिने जेथे तारण ठेवले आहेत त्या शाखेस भेट द्यावी किंवा संबंधित शाखेच्या सदर नामनिर्णयत अधिकार्यांच्या खाती नमूद क्रमांकावर संपर्क साधावा. विहित कालावधीत थकबाकीचा भरणे न केल्याने आयसीआयसीआय एचएफसी हे लिलावाच्या माध्यमातून आम जनतेस / बोलीदारांना सोन्याच्या दागिन्यांची विक्री करतील. लिलाव हा शुक्रवार, ०४ नोव्हेंबर, २०२२ रोजी दु. १२.३० ते ३.३० वाजेपर्यंत <https://gold.samil.in> येथे ऑनलाईन राबविण्यात येईल.

शाखा - पुणे - मेन संपर्क क्र. - ८९८३३०४४६१ सुवर्ण कर्ज खाते - १२००००३३८९५

ही विक्री आयसीआयसीआय एचएफसी यांच्या पुढीलच्या अधीन असेल आणि आयसीआयसीआय एचएफसी चे प्राधिकृत अधिकारी कुठलेही कारण न देता कोणतीही किंवा सर्व बोली फेटाळण्याचा अधिकार राखून ठेवतात.

लिलाव हा <http://gold.samil.in> च्या माध्यमातून ऑनलाईन राबविण्यात येईल, कोणत्याही कारणांस्तव लिलाव दिलेल्या दिवशी पूर्ण न झाल्यास हा लिलाव पुढील कामकाजाच्या दिवशी राबविण्यात येईल. स्थान किंवा दिनांक आणि विक्रीच्या अटी व शर्तीमध्ये काही बदल झाल्यास तो आमच्या वेबसाईटवर www.icicifnc.com येथे कळविण्यात येईल.

या संदर्भात पुढे कोणताही संचार जारी करण्यात येणार नाही.

दिनांक: २१.१०.२०२२

स्थान: महाराष्ट्र

स्वा/-

प्राधिकृत स्वाक्षरीकार

आयसीआयसीआय होम फायनान्स कंपनी लिमिटेड करिता

जाहीर सूचना

याद्वारे सूचना देण्यात येत आहे की, आमच्या अशीलंज्या सूचनेवरून खाली नमूद केलेल्या परिशिष्टात अधिक स्पष्टपणे विनिर्दिष्ट केलेल्या निवासी प्रिमायसेस यापुढे सदर मालमत्ता म्हणून संबोधित संदर्भात मेरिट डेव्हलपर्स प्रायव्हेट लिमिटेड यांच्या हक्कांची चौकशी करित आहोत.

सर्व व्यक्ती ज्यांचे सदर मालमत्ता आणि/किंवा मालमत्ते बाबतीत वारसा, गहाण, कब्जा, संपादन, विक्री, भेट, भाडेपट्टा, उपभाडेपट्टा, जप्ती, कुळबहिवाट, अदलाबदल, वारसा, सक्शेशन, धारणाधिकार, प्रभार, देखभाल, लिसपॅडन्स, अटॅचमेंट, परवाना, डिक्ली किंवा कोर्टाचे अन्य आदेश ट्रिब्युनल किंवा अन्यथा कोणत्याही मागिने हक्क, नामाधिकार, हितसंबंध, दावा किंवा मागणी असल्यास त्यांनी निम्नस्वक्षरीकारांना लिखित स्वरूपात सदर सूचना प्रकाशनाच्या १० (दहा) दिवसांत प्रमाणिगत प्रती आणि पुरक दस्तावेज सोबत खालील पत्त्यावर कळवणे, अन्यथा सदर मालमत्ता सर्व बोजांपासून मुक्त आहे असे समजण्यात येईल आणि कोणतेही हक्क, नामाधिकार फायदा हितसंबंध दावा मागणी असल्यास ते त्यागीत आणि / किंवा परित्यागीत केले आहेत असे समजले जाईल आणि सदर मालमत्तेच्या हक्कांची चौकशीची प्रक्रीया पूर्ण केली जाईल.

परिशिष्ट

(सदर मालमत्तेचा तपशील)

महाराष्ट्र राज्यातील जिल्हा आणि तालुका पूणे येथील गाव धोरपडी बोट क्लब रोडवरील ऑरिजिन नगर नियोजन योजनाचा प्लॉट क्रमांक २१९, सर्व क्रमांक ३५८, सीटीएस क्रमांक १० धारक जमिनीचे सर्व भाग व तुकड्यांवर बांधण्यात आलेल्या २१९ बोट क्लब च्या २ व्या मजल्या मोजमापीत ५८९.१७ चौरस मीटरस चर्टई क्षेत्राचा निवासी प्रिमायसेस क्रमांक २०९.

Covid pandemic not over yet; few nations likely to see wave of infections:



tender fees Rs. 4720/-
Other terms & conditions have been given in detailed tender for which please visit us at our website www.rmm.com or www.appp.rajasthan.gov.in or eproc.rajasthan.gov.in or contact GGM (Contract) on above address.
DGM (Admin.)

8. The Bidders have to participate in ONLINE bidding only. Further details can be seen from the website <https://tendersonline.gov.in> Any addendum/corrigendum/cancellation of tender can also be seen in the said web site.

Sd/- P.K. Pradhan
Chief Construction Engineer,
Cuttack(R&B)Circle
OIPR-34012/11/0015/2223

PUBLIC NOTICE
This is to inform the public in general that Akanksha Builders have been accorded with the Environmental Clearance by State Environment Impact Assessment Authority, Maharashtra (Government of Maharashtra for their construction project at S. No. 70/1 & 65/1/1B, Mouje Wakad, Tal. Mulashi Dist. Pune letter No.EC228038MH15817). This clearance is in accordance with the provisions of 'EIA Notification 2006. The copies of this letter are available with Maharashtra Pollution Control Board and may also be seen Department of Environment, Government of Maharashtra website <http://parivesh.nic.in>

LONAVLA MUNICIPAL COUNCIL
e-Tender Notice for 2022-2023
Lonavla Municipal Council, Lonavla, Tal. Maval, Dist. Pune invites e-Tender for the work in Water Supply Department with Tender Notice LMC-7/e-Tender Notice No. 3/2022-23/2012, Dated 20/10/2022 in State of Maharashtra.
Please visit website www.mahatender.gov.in (Tender by Location- Lonavla) for the more details published on Date 21/10/2022.
Sd/- **Yashwant Munde**
Engineer
Water Supply
Department
Sd/- **Pandit Patil**
Chief Officer and
Administrator
Lonavla Municipal
Corporation

M.P. STATE BIODIVERSITY BOARD
26, Kisan Bhawan, First Floor, Arera Hills, Bhopal-462011
Website : www.mpsbb.nic.in, Email : mpsbb@mp.gov.in
Phone No. : 0755 - 2554549 / 2554539
No. MPSBB/(C&D)/RFP/2022/3518 Bhopal, Dtd. : 19.10.2022
REQUEST FOR PROPOSAL (RFP)
Madhya Pradesh State Biodiversity Board (MPSBB) invites Request for Proposal (RFP) for preparation of Detailed Project Report (DPR) for the establishment of "Biodiversity Park at Shahpura, Bhopal, Madhya Pradesh". The detailed information is available on e-tender portal www.mptenders.gov.in and MPSBB website www.mpsbb.nic.in.
M.P. Madhyam/106951/2022 **MEMBER SECRETARY**

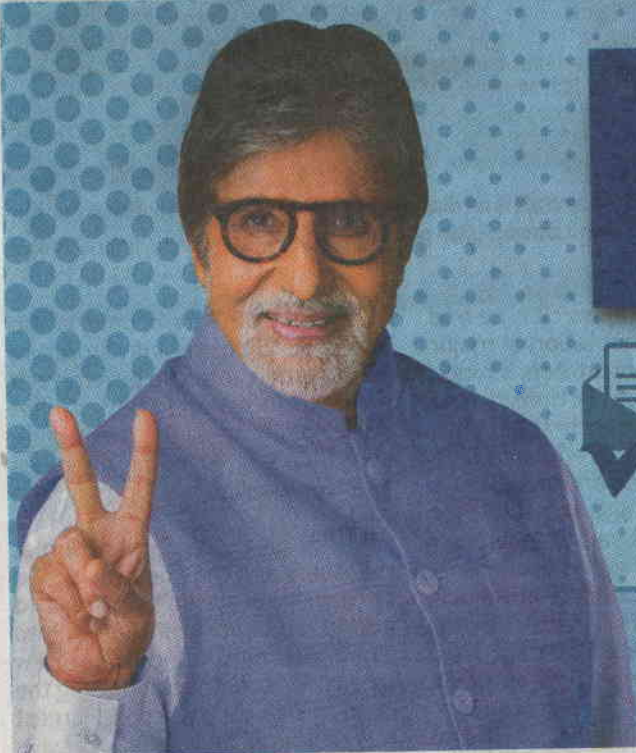

Reserve Bank - Integrated
Single window for resolution of complaints



Complaints not resolved within 30 days by banks/NBFCs/system participants lodged with the Ombudsman

For more information call 14448. To lodge a complaint visit www.ombudsman.gov.in



For more details, visit www.ombudsman.gov.in
For feedback, write to ombudsman@ombudsman.gov.in



Annexure VII: Consent Certificate

MAHARASHTRA POLLUTION CONTROL BOARD

Tel: 24010706/24010437
Fax: 24044532/4024068/4023516
Website: <http://mpcb.gov.in>
Email: jdwater@mpcb.gov.in



Kalpataru Point, 2nd and
4th floor, Opp. Cine Planet
Cinema, Near Sion Circle,
Sion (E), Mumbai-400022

Infrastructure/RED/L.S.I

No:- Format1.0/JD (WPC)/UAN No.0000118095/CE - 2111000788

Date: 18.11.2021

To,
M/s Akanksha Builders
Proposed residential cum commercial
construction building project
S. No. 70/1 and S. No. 65/1/1B, Mouje
Wakad,
Tal. Mulshi, Dist. Pune



Your Service is Our Duty

Sub: Consent to Establish for residential and commercial construction project in Red Category

Ref: 1. Application submitted by SRO Pimpri Chinchwad, Pune

Your application NO. MPCB-CONSENT-0000118095

For: grant of Consent to Establish under Section 25 of the Water (Prevention & Control of Pollution) Act, 1974 & under Section 21 of the Air (Prevention & Control of Pollution) Act, 1981 and Authorization / Renewal of Authorization under Rule 6 of the Hazardous & Other Wastes (Management & Transboundary Movement) Rules 2016 is considered and the consent is hereby granted subject to the following terms and conditions and as detailed in the schedule I,II,III & IV annexed to this order:

1. The consent is granted for period upto commissioning of the project or five years whichever is earlier
2. The capital investment of the project is Rs.78 Cr. (As per C.A Certificate submitted by industry).
3. The Consent to Establish is valid for Proposed residential cum commercial construction building construction project at wakad by M/s Akanksha Builders, S. No. 70/1 and S. No. 65/1/1B,1B, Mouje Wakad, Tal. Mulshi, Dist. Pune on Total Plot Area of 12491.72 SqMtrs for construction BUA of 64500 SqMtrs including utilities and services
4. Conditions under Water (P&CP), 1974 Act for discharge of effluent:

Sr No	Description	Permitted (in CMD)	Standards to	Disposal
1.	Trade effluent	Nil	NA	NA
2.	Domestic effluent	264	As per Schedule - I	The treated effluent shall be 60% recycled for secondary purposes such as toilet flushing, air conditioning, cooling tower make up, firefighting etc. and remaining shall be connected to the sewerage system provided by local body

5. Conditions under Air (P& CP) Act, 1981 for air emissions:

Stack No.	Description of stack / source	Number of Stack	Standards to be achieved
S-1	DG Set- 225 KVA	01	As per Schedule -II
S-2	DG Set- 225 KVA	01	As per Schedule -II

6. Conditions under Solid Waste Rules, 2016:

Sr No	Type Of Waste	Quantity & UoM	Treatment	Disposal
1	Biodegradable waste	651 Kg/Day	Organic waste Converter with composting facility / Biogas digester with composting facility	As Manure for gardening
2	Non Biodegradable waste	487 Kg/Day	Segregation	Send to authorized vendor
3	STP Sludge	23 Kg/Day	Dewatering	As Manure

7. Conditions under Hazardous & Other Wastes (M & T M) Rules 2016 for treatment and disposal of hazardous waste:

Sr No	Category No.	Quantity	UoM	Treatment	Disposal
1	S.1 Used or spent oil	50	Ltr/A	Reprocessing	To Authorized Reprocessor

- This Board reserves the right to review, amend, suspend, revoke etc. this consent and the same shall be binding on the industry.
- This consent should not be construed as exemption from obtaining necessary NOC/permission from any other Government agencies.
- Project Proponent shall install online monitoring system for the parameter pH, SS, BOD and flow at the outlet of STP.
- Project Proponent shall provide Organic waste digester with composting facility or biodigester with composting facility.
- Project Proponent shall comply the Construction and Demolition Waste Management Rules, 2016 which is notified by Ministry of Environment, Forest and Climate Change dtd.29/03/2016.
- The project proponent shall make provision of charging of electric vehicles in atleast 40 % of total available parking area.
- The project proponent shall take adequate measures to control dust emission and noise level during construction phase.
- PP shall obtain Environmental Clearance from competent authority for the proposed activity. PP shall not take effective steps towards construction without obtaining Environmental Clearance.
- PP shall submit an affidavit in Boards prescribed format within 15 days regarding compliance of C to E.

For and on behalf of the
Maharashtra Pollution Control Board.

Dr. Y.B.Sontakke
Joint Director (WPC)



Received Consent fee of -

Sr.No	Amount(Rs.)	Transaction/DR.No.	Date	Transaction Type
1	125000.00	TXN2107002301	22/07/2021	Online Payment

Copy to:

1. Regional Officer, MPCB, Pune and Sub-Regional Officer, MPCB, Pune II
- They are directed to ensure the compliance of the consent conditions.
2. Chief Accounts Officer, MPCB, Sion, Mumbai



SCHEDULE-I

Terms & conditions for compliance of Water Pollution Control:

- 1) A) As per your application, you have proposed to provide Two Sewage Treatment Plant (STPs) with design capacity of 250 CMD & 30 CMD based on MBBR
- B) The Applicant shall operate the sewage treatment plant (STP) to treat the sewage so as to achieve the following standards prescribed by the Board or under EP Act, 1986 and Rules made there under from time to time, whichever is stringent.

Sr.No	Parameters	Limiting concentration not to exceed in mg/l, except for pH
1	pH	5.5-9.0
2	BOD	10
3	COD	50
4	TSS	20
5	NH4 N	5
6	N-total	10
7	Fecal Coliform	less than 100

- C) The treated domestic effluent shall be 60% recycled for secondary purposes such as toilet flushing, air conditioning, cooling tower make up, firefighting etc. and remaining shall be utilized on land for gardening and connected to the sewerage system provided by local body.
- 2) The Board reserves its rights to review plans, specifications or other data relating to plant setup for the treatment of waterworks for the purification thereof & the system for the disposal of sewage or trade effluent or in connection with the grant of any consent conditions. The Applicant shall obtain prior consent of the Board to take steps to establish the unit or establish any treatment and disposal system or and extension or addition thereto.
- 3) The industry shall ensure replacement of pollution control system or its parts after expiry of its expected life as defined by manufacturer so as to ensure the compliance of standards and safety of the operation thereof.
- 4) **The Applicant shall comply with the provisions of the Water (Prevention & Control of Pollution) Act, 1974 and as amended, and other provisions as contained in the said act.**

Sr. No.	Purpose for water consumed	Water consumption quantity (CMD)
1.	Industrial Cooling, spraying in mine pits or boiler feed	0.00
2.	Domestic purpose	192.00
3.	Processing whereby water gets polluted & pollutants are easily biodegradable	0.00
4.	Processing whereby water gets polluted & pollutants are not easily biodegradable and are toxic	0.00

- 5) The Applicant shall provide Specific Water Pollution control system as per the conditions of EP Act, 1985 and rule made there under from time to time.



SCHEDULE-II

Terms & conditions for compliance of Air Pollution Control:

- 1) As per your application, you have proposed to provide the Air pollution control (APC) system and also proposed to erect following stack (s) and to observe the following fuel pattern-

Stack No.	Stack Attached To	APC System	Height in Mtrs.	Type of Fuel	Quantity & UoM
S-1	DG Set- 225 KVA	Acoustic Enclosure	3.0	HSD	38.6 Ltr/Hr
S-2	DG Set- 225 KVA	Acoustic Enclosure	3.0	HSD	38.6 Ltr/Hr

- 2) The applicant shall operate and maintain above mentioned air pollution control system, so as to achieve the level of pollutants to the following standards.

Total Particular matter	Not to exceed	150 mg/Nm ³
-------------------------	---------------	------------------------

- 3) The Applicant shall obtain necessary prior permission for providing additional control equipment with necessary specifications and operation thereof or alteration or replacement well before its life come to an end or erection of new pollution control equipment.
- 4) The Board reserves its rights to vary all or any of the condition in the consent, if due to any technological improvement or otherwise such variation (including the change of any control equipment, other in whole or in part is necessary).
- 5) **Conditions for utilities like Kitchen, Eating Places, Canteens:-**
- The kitchen shall be provided with exhaust system chimney with oil catcher connected to chimney through ducting.
 - The toilet shall be provided with exhaust system connected to chimney through ducting.
 - The air conditioner shall be vibration proof and the noise shall not exceed 68 dB(A).
 - The exhaust hot air from A.C. shall be attached to Chimney at least 5 mtrs. higher than the nearest tallest building through ducting and shall discharge into open air in such a way that no nuisance is caused to neighbors.

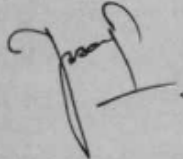



SCHEDULE-III
Details of Bank Guarantees:

Sr. No.	Consent(C2E/C2O/C2R)	Amt of BG Imposed	Submission Period	Purpose of BG	Compliance Period	Validity Date
1	Consent to Establish	Rs 10 Lakhs	15 Days	Compliance of Consent Conditions	upto Commissioning of the project	5 Yrs

** The above Bank Guarantee(s) shall be submitted by the applicant in favour of Regional Officer at the respective Regional Office within 15 days of the date of issue of Consent.
Existing BG obtained for above purpose if any may be extended for period of validity as above.

BG Forfeiture History

Srno.	Consent (C2E/C2O/C2R)	Amount of BG imposed	Submission Period	Purpose of BG	Amount of BG Forfeiture	Reason of BG Forfeiture
NA						

BG Return details

Srno.	Consent (C2E/C2O/C2R)	BG imposed	Purpose of BG	Amount of BG Returned
NA				



[Handwritten signature]

SCHEDULE-IV

Conditions during construction phase

A	During construction phase, applicant shall provide temporary sewage and MSW treatment and disposal facility for the staff and worker quarters.
B	During construction phase, the ambient air and noise quality shall be maintained and should be closely monitored through MoEF approved laboratory.
C	Noise should be controlled to ensure that it does not exceed the prescribed standards. During night time the noise levels measured at the boundary of the building shall be restricted to the permissible levels to comply with the prevalent regulations.

General Conditions:

- 1 The applicant shall provide facility for collection of samples of sewage effluents, air emissions and hazardous waste to the Board staff at the terminal or designated points and shall pay to the Board for the services rendered in this behalf.
- 2 The firm shall strictly comply with the Water (P&CP) Act, 1974, Air (P&CP) Act, 1981 and Environmental Protection Act 1986 and Solid Waste Management Rule 2016, Noise (Pollution and Control) Rules, 2000 and E-Waste (Management & Handling Rule 2011.
- 3 Drainage system shall be provided for collection of sewage effluents. Terminal manholes shall be provided at the end of the collection system with arrangement for measuring the flow. No sewage shall be admitted in the pipes/sewers downstream of the terminal manholes. No sewage shall find its way other than in designed and provided collection system.
- 4 Vehicles hired for bringing construction material to the site should be in good condition and should conform to applicable air and noise emission standards and should be operated only during non-peak hours.
- 5 Conditions for D.G. Set
 - a) Noise from the D.G. Set should be controlled by providing an acoustic enclosure or by treating the room acoustically.
 - b) Industry should provide acoustic enclosure for control of noise. The acoustic enclosure/ acoustic treatment of the room should be designed for minimum 25 dB (A) insertion loss or for meeting the ambient noise standards, whichever is on higher side. A suitable exhaust muffler with insertion loss of 25 dB (A) shall also be provided. The measurement of insertion loss will be done at different points at 0.5 meters from acoustic enclosure/room and then average.
 - c) Industry should make efforts to bring down noise level due to DG set, outside industrial premises, within ambient noise requirements by proper siting and control measures.
 - d) Installation of DG Set must be strictly in compliance with recommendations of DG Set manufacturer.
 - e) A proper routine and preventive maintenance procedure for DG set should be set and followed in consultation with the DG manufacturer which would help to prevent noise levels of DG set from deteriorating with use.
 - f) D.G. Set shall be operated only in case of power failure.
 - g) The applicant should not cause any nuisance in the surrounding area due to operation of D.G. Set.
 - h) The applicant shall comply with the notification of MoEFCC, India on Environment (Protection) second Amendment Rules vide GSR 371(E) dated 17.05.2002 and its amendments regarding noise limit for generator sets run with diesel.

- 6 Solid Waste - The applicant shall provide onsite municipal solid waste processing system & shall comply with Solid Waste Management Rule 2016 & E-Waste (M & H) Rule 2011.
- 7 Affidavit undertaking in respect of no change in the status of consent conditions and compliance of the consent conditions the draft can be downloaded from the official web site of the MPCB.
- 8 Applicant shall submit official e-mail address and any change will be duly informed to the MPCB.
- 9 The treated sewage shall be disinfected using suitable disinfection method.
- 10 The firm shall submit to this office, the 30th day of September every year, the environment statement report for the financial year ending 31st march in the prescribed Form-V as per the provision of rule 14 of the Environmental (Protection) Second Amended rule 1992.
- 11 The applicant shall obtain Consent to Operate from Maharashtra Pollution Control Board before commissioning of the project.

For and on behalf of the
Maharashtra Pollution Control Board.

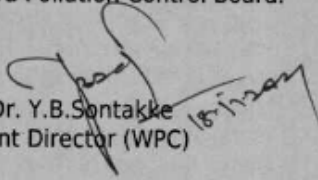
Dr. Y.B. Sontakke
Joint Director (WPC)

